

Futaba

Electronic Switch Harness

ESW-1J/ESW-1D

Instruction Manual

Thank you for purchasing the Electronic Switch Harness. This switch connects a Futaba receiver to a battery and is turned on and off in an FET circuit. Compared to using a mechanical switch, it allows more current to be sent with less loss. After reading this manual, store it in a safe place for future reference.

Precautions

⚠️ WARNNG

- ❗ **When the model is not being used, always remove or disconnect the battery.**
 - When the switch is off, a slight amount of current still flows. Unless the switch and battery are disconnected, the battery will be damaged from excessive discharge.
- ❗ **Always make sure that the switch harness is firmly attached to the fuselage of the model.**
 - There is the danger of loss of control and crashing if the connector is disconnected by vibration and shock.
- ⊘ **Do not charge the receiver battery through the switch harness. Disconnect the receiver battery and charge to the manufactures instructions.**
 - There is no charge connector in this switch.
- ⊘ **Never reverse the battery polarity.**
 - Reverse connection will immediately destroy the receiver, servo, etc.

- ❗ **Ensure that the unit is mounted in an area that will eliminate exposure to fuel, water and vibration.**
 - As with any electronic components, proper precautions are urged to prolong the life and increase the performance of the ESW-1J/ESW-1D.
- ❗ **Allow a slight amount of slack in the cables and fasten them at a suitable location to prevent any damage from vibration during flight.**
- ⊘ **Never solder the ESW-1J/ESW-1D or attempt to repair, deform, modify or disassemble them.**
- ⊘ **Do not use the ESW-1J/ESW-1D with anything other than an R/C model.**

Futaba Corp. will not be responsible for damage caused by combination with other than genuine Futaba parts.

Name of Each Part

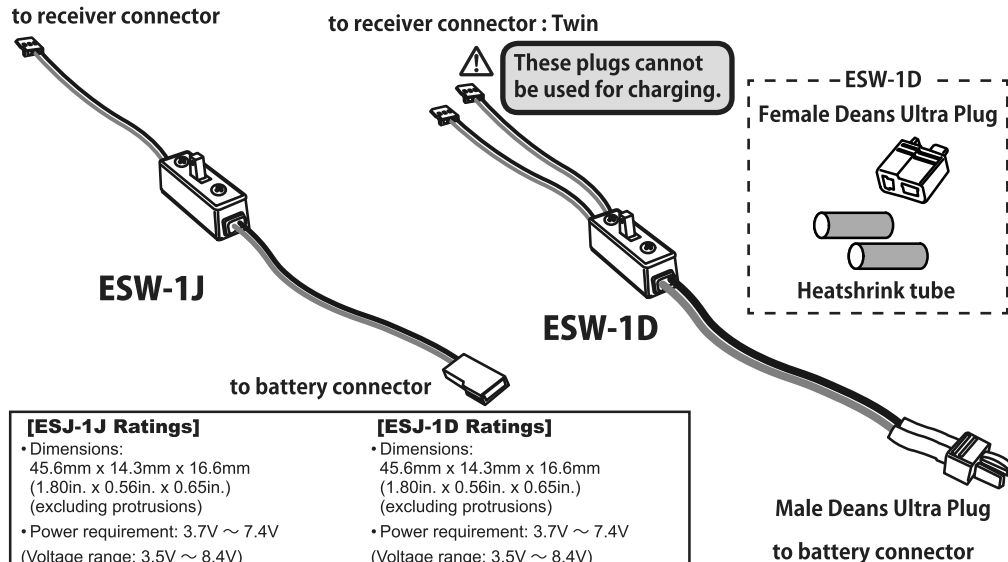

[ESJ-1J Ratings]

- Dimensions: 45.6mm x 14.3mm x 16.6mm (1.80in. x 0.56in. x 0.65in.) (excluding protrusions)
- Power requirement: 3.7V ~ 7.4V (Voltage range: 3.5V ~ 8.4V)
- Allowable current: ~ 5A (Maximum allowable current: 10A 30s)

[ESJ-1D Ratings]

- Dimensions: 45.6mm x 14.3mm x 16.6mm (1.80in. x 0.56in. x 0.65in.) (excluding protrusions)
- Power requirement: 3.7V ~ 7.4V (Voltage range: 3.5V ~ 8.4V)
- Allowable current: ~ 10A (Maximum allowable current: 15A 30s)

Connections

